

INSTALLATION INSTRUCTIONS

- **Easy module replacement**
 - **Modern and compact design**
 - **Full encapsulated for moisture, vibration and corrosion resistance**
 - **Excellent water resistance with waterproof modules and socket connectors**
 - **Hard-coated lenses and aluminum housing minimize environmental damage**
 - **Different lengths to choose from: 25.4", 36", 48", 53", 59", 71"**
 - **Synchronize to other 911Signal products**
-

 **LURKER**

LED Lightbar



Product Specifications

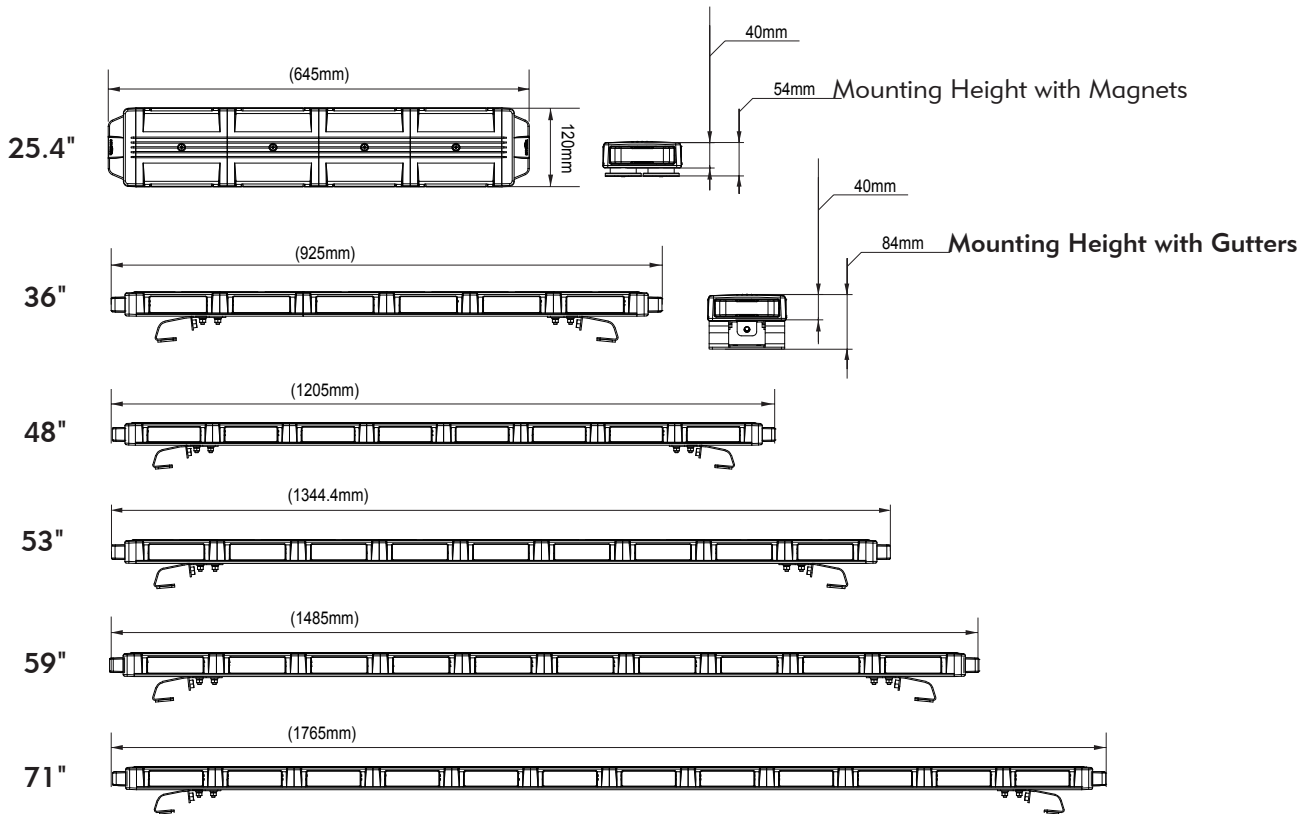

Mounting

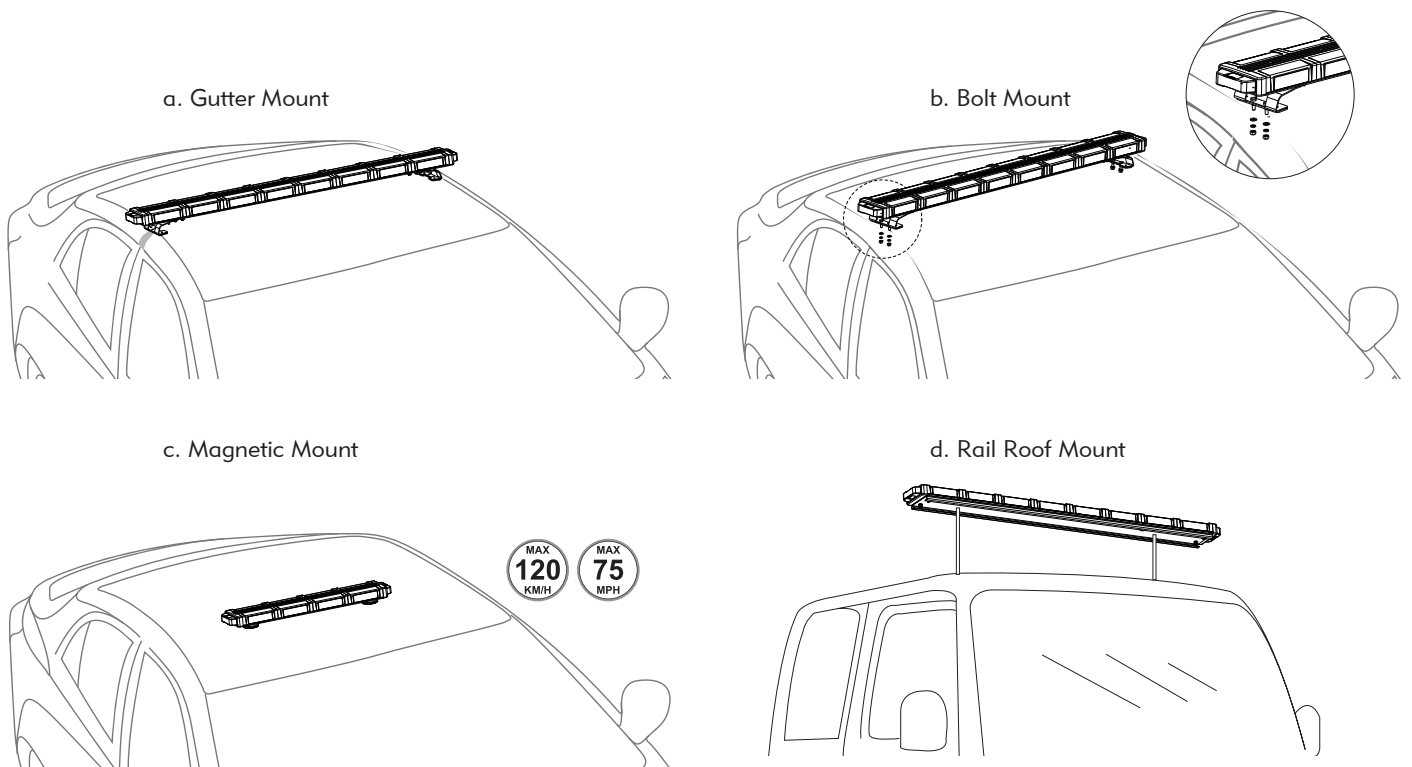

Frequently check to ensure the physical integrity and proper tightness of mounting hardware

Wiring & Flash &

Wiring

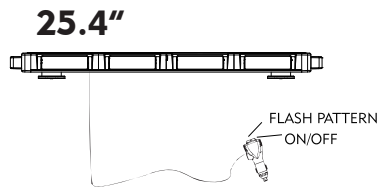
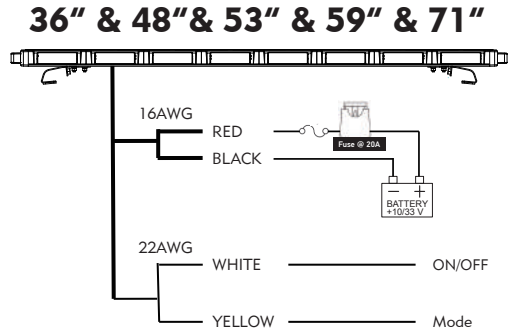
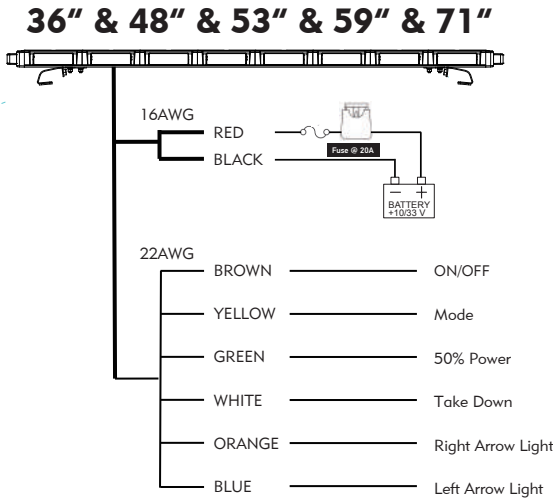

Model	Voltage	Max Power	Fuse
25.4"	DC 10-33V	85W	10A
36"	DC 10-33V	115W	15A
48"	DC 10-33V	145W	15A
53"	DC 10-33V	160W	20A
59"	DC 10-33V	175W	20A
71"	DC 10-33V	205W	25A

WARNING: Power input end must be connected to the proper safety fuse.

Flash Patterns

- | | | |
|---------------------------|-------------------------|----------------------|
| 1. Random (Default) | 10. Quint (ALL) | 19. Quad (I/O) |
| 2. ECE R65 Rotator | 11. Single-Quad (ALL) | 20. Quint (I/O) |
| 3. ECE R65 single (ALL) | 12. Single (Split) | 21. Single (Split1) |
| 4. ECE R65 Double (ALL) | 13. Double (Split) | 22. Double (Split1) |
| 5. ECE R65 single (Split) | 14. Quad (Split) | 23. Quad (Split1) |
| 6. ECE R65 Double (Split) | 15. Quint (Split) | 24. Quint (Split1) |
| 7. Single (ALL) | 16. Single-Quad (Split) | *25. Single (Split2) |
| 8. Double (ALL) | 17. Single (I/O) | *26. Double (Split2) |
| 9. Quad (ALL) | 18. Double (I/O) | *27. Quad (Split2) |
| | | *28. Quint (Split2) |

LURKER 53" doesn't include these * four flash patterns

Maintenance

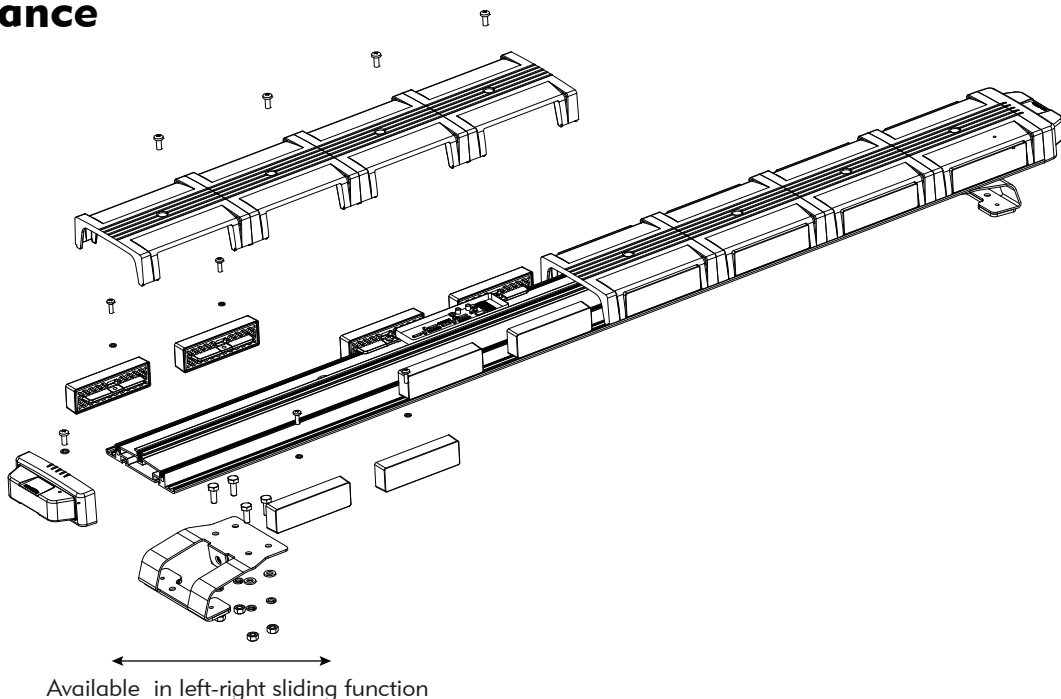



Your Innovative and
Reliable Partner

www.911signal.com



Scan QR Code and Get a Free
One-Year Extension
of Warranty

911 Signal Technology Inc.

Add: Room 701-702, Hengwei Building, No.258, Tiangao Lane,
Shouan Subdistrict, Yinzhou Area, Ningbo City, Zhejiang, China.

Tel: +86-574-8901 7911 +86-400 6757 911

Fax: +86-574-8282 2560

E-mail: sales@911signal.com